

## ZAXIS160LCT

A P P L I C A T I O N

## Telescopic Crawler Crane

ZAXIS160LCT Rated Lifting Capacity 8 Tons

Lifting load: 8.0 t x 2.5 m  
Working radius: 0.9 t x 13.2 m

4 Stages Boom

8t



## Variety of Safety Devices

Moment limiter, working range limiter, hook overhoist prevention device, external load ratio indicator.

## Notes:

1. Never leave the front attachment in a raised position. Make sure the front attachment is lowered to the ground before leaving the equipment unattended. (Some of the pictures in this catalog show an unmanned machine with attachments in an operating position. These were taken for demonstration purposes only and the actions shown are not recommended under normal operating conditions.)
2. Caution plates on the machine will vary according to country.
3. Photos include optional equipment.

## Moment Limiter

To prevent tipping-over due to overload, sounds buzzer and stops crane operation automatically (hook hoisting, boom lowering and boom extending) when reaching the limit. Indicates digitally the rated load, actual load, working radius, boom length and boom angle. Also, indicates the load factor.



Moment limiter

## Working Range Limiter

Can set arbitrarily the boom angle (upper and lower limits) and maximum working radius. Stops crane operation automatically when exceeding the setting for smooth, dependable working near power lines and elevated structures.

*Safe Load Indicator may vary per country.*

## Dimensions

Unit: mm

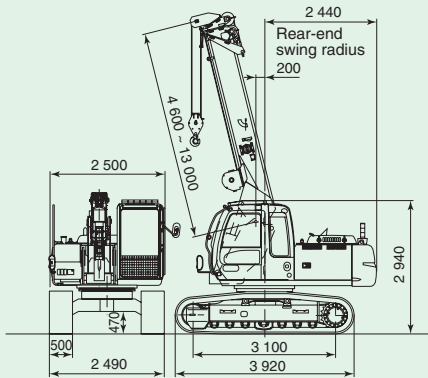

## Working Range Diagram

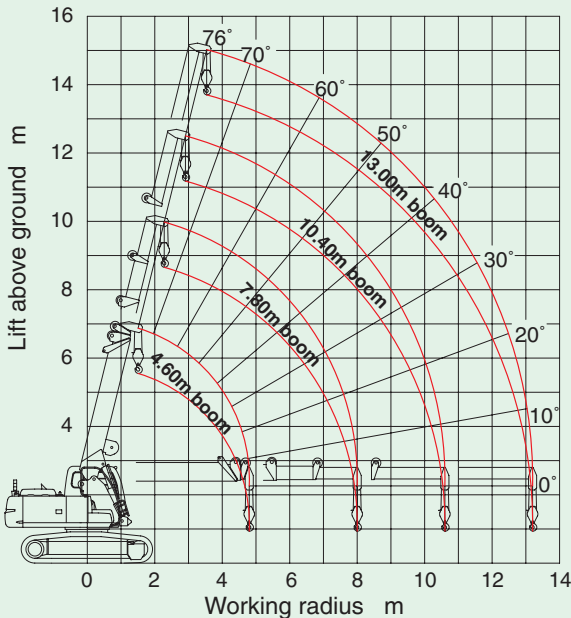

### Notes:

1. This graph shows working ranges with the load, and does not include jib deflection.
2. The crane can be operated with the load in the range of 0° to 76°.

## Specifications

		ZAXIS160LCT Grouser shoe
Operating weight	kg	15 400
Overall transport length	mm	7 360
Max. lifting load x working radius	t x m	8.0 x 2.5
Max. hook lift above ground level	m	13.7 * (5 reeving)
Max. hook lift below ground level	m	18.0 * (5 reeving)
Boom length	m	4.6~13.0
Boom hoist angle	degree	-3°~-76°
Boom hoisting speed	s	10.0 (-3°~-76°)
Boom extending speed	m/s	8.4 / 14.0
Hoisting rope speed	m/min	High 97 / Low 66
Hoisting rope	φmm/m	10 x 111
Swing speed	min <sup>-1</sup> (rpm)	2.0 (2.0)
Travel speed	km/h	3.0
Engine Model		Isuzu AA-4BG1TC
Rated output	kW/min <sup>-1</sup> (PS/rpm)	81 / 2 150 (110 / 2 150)

The machine shown may vary according to territory Specifications.

### Note:

\*When hook lift becomes large, the rope is likely to be easily kinked.

1. Data shown above are in SI units, followed by data in conventional units in ( ).

## Crane ratings ZAXIS160LCT

Unit: kg

Working radius m	Boom length			
	4.6 m	7.8 m	10.4 m	13.0 m
1.50	8 000			
2.00	8 000			
2.50	8 000			
2.70	7 600	7 000		
3.00	7 000	7 000		
3.50	5 500	5 500	4 900	
4.00	4 900	4 900	4 900	3 900
4.50	4 150	4 250	4 300	3 900
4.80	3 775	-	-	-
5.00		3 650	3 650	3 650
6.00		2 820	2 820	2 820
6.50		2 500	2 500	2 500
7.00		2 250	2 250	2 250
8.00		1 820	1 820	1 820
9.00			1 550	1 550
10.00			1 320	1 320
10.60			1 220	1 220
11.00				1 160
12.00				1 020
13.00				920
13.20				900

Hooks		Number of hoist reeving and max. rated loads (kg)				
Cap.	Weight	5	4	3	2	1
8.0 ton	75 kg	8 000	6 400*	4 800*	3 200	1 600

### Notes:

1. The rated loads are determined according to DIN 15018 part 3 (lifting class H2, loading group B2). The stability is according to EN13000 (2004). The rated loads listed are based on the condition that the machine is stationed on firm, level ground. The rated loads are available over 360 degrees. The rated loads shown include the weight of all lifting attachments such as hook and bucket. The load to be actually lifted is the rated load minus the weight of all lifting attachments.
2. Counterweight is 3 040 kg fixed to crane.
3. Travelling with 75% of rated load is allowed and provided that:
  - surface must be firm and level;
  - the boom is in travelling direction and upper carriage locked;
  - speed is not above 0.4 m/s (on a firm level ground);
  - the load is near the ground (0.5 m) and secured against swinging;
  - no other movement are allowed.
4. At windforce of 14 m/s or more the operation must be stopped. By windforce of 15 m/s or more the boom must be retracted to the minimum and lowered to the ground.
5. For the wind load area of the rated load is 1.2 m<sup>2</sup> per 1 000 kg calculated.

\* Standard reeving for working 1-2 or 5 reeving, for special cases 3 and 4 reevings possible to work.

These specifications are subject to change without notice.

Illustrations and photos show the standard models, and may or may not include optional equipment, accessories, and all standard equipment with some differences in color and features. Before use, go through Operator's Manual for proper operation.

## Hitachi Construction Machinery (Europe) NV

Souvereinstraat 16, 4903 RH Oosterhout, P.O. Box 404,4900AK Oosterhout, (The Netherlands)

Telephone : +31(0)162 48 4400

Facsimile : +31(0)162 45 74 53

URL : www.hcme.com

Sicliëweg 5, Haven 5112, 1045 AT Amsterdam, P. O. Box 59239,1040 KE Amsterdam,(The Netherlands)

Telephone : +31(0)20 44 76 700

Facsimile : +31(0)20 33 44 045

URL : www.hcme.com